



TRIAC overvoltage protection using a Transil™

Introduction

In most of their applications, TRIACs are directly exposed to overvoltages coming from the mains, as described in IEC 61000-4-5 or IEC 61000-4-4 standards. When TRIACs are used to drive resistive loads (ex: temperature regulation), it is essential to provide them with efficient overvoltage protection to prevent any turn-on in breakover mode that could lead to device damage.

A traditional method to clamp the voltage is to use a varistor in parallel across the TRIAC. But with high power loads (a few kW), the current through the varistor is very high in case of surge voltages (a few hundred amperes). The varistor is then not efficient enough, due to its dynamic resistor, to limit the TRIAC voltage to a low value.

We present here a solution that can be used for these kinds of applications and also for all applications where TRIAC voltage protection is required.

It should be noted that the overvoltages could also come from the overvoltages that appear at device turn-off due to the TRIAC holding current. This phenomenon occurs mainly with TRIACs controlling low rms current (15-50 mA), high inductive loads like valves. For more information about such behavior, please refer to AN1172.

Contents

1	Why overvoltage protection is required	2
2	Overvoltage protection solution	3
3	Transil choice for efficient TRIAC voltage protection	6
3.1	Normal operation: check V_{RM} voltage	6
3.2	Surge voltage clamping: check max V_{CL} voltage	6
4	Experimental validation example	8
5	Conclusion	12
6	Revision history	13

1 Why overvoltage protection is required

In a typical circuit (see [Figure 1.](#)), a surge voltage superimposed on the network voltage can turn the TRIAC on by exceeding its breakdown voltage.

Under these conditions, because of its internal structure, only a part of the TRIAC is effectively turned on and the TRIAC can thus withstand only a very low di/dt. This explains the high risk of component damage when TRIACs are used to drive purely resistive loads. The di/dt can, in this case, reach very high values (> 100 A/μs) since only the inductance of the connections limits the current rate of increase.

Figure 1. Typical TRIAC application circuit without overvoltage protection (risk of damage)

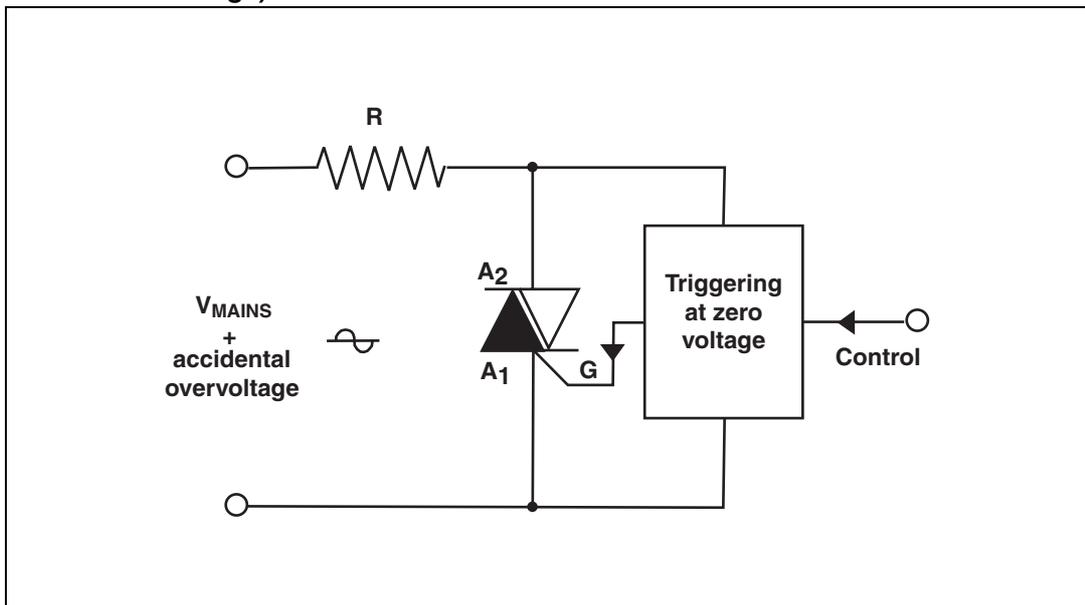

2 Overvoltage protection solution

The principle of the protection we propose here consists of turning on the TRIAC by the gate as soon as the voltage across it exceeds a certain value. Such a principle can be easily implemented with a low-cost circuit (see [Figure 2](#) for schematic diagram). This circuit uses a bidirectional Transil diode whose current/voltage characteristic is shown in [Figure 3](#).

When the TRIAC voltage reaches the Transil V_{BR} voltage, the Transil conducts, then provides the TRIAC gate with current and turns it on (see [Figure 4](#)). The TRIAC remains on till the half cycle current passes through zero (see [Figure 5](#)).

Figure 2. Protection of the TRIAC by a bidirectional Transil diode

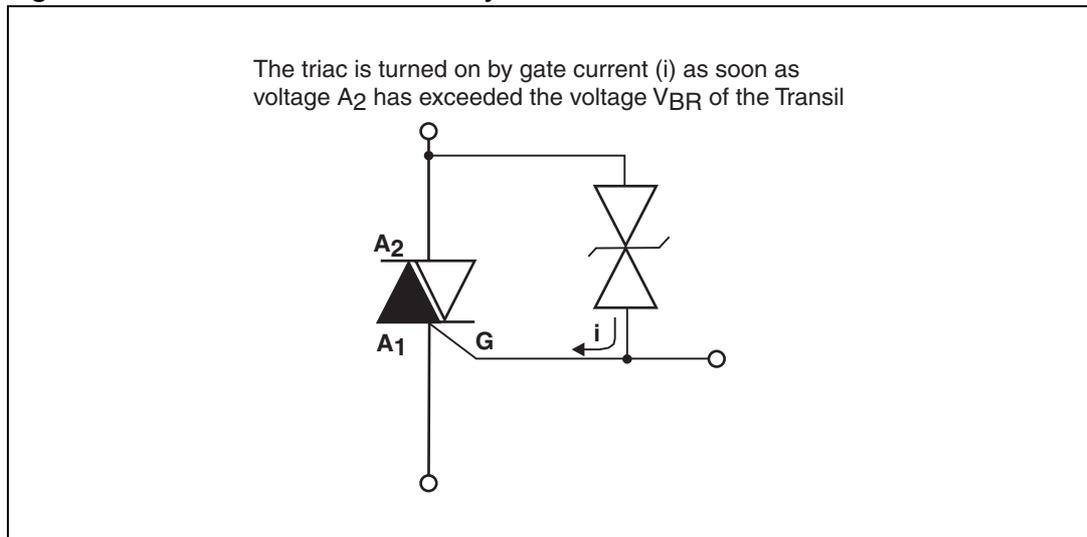
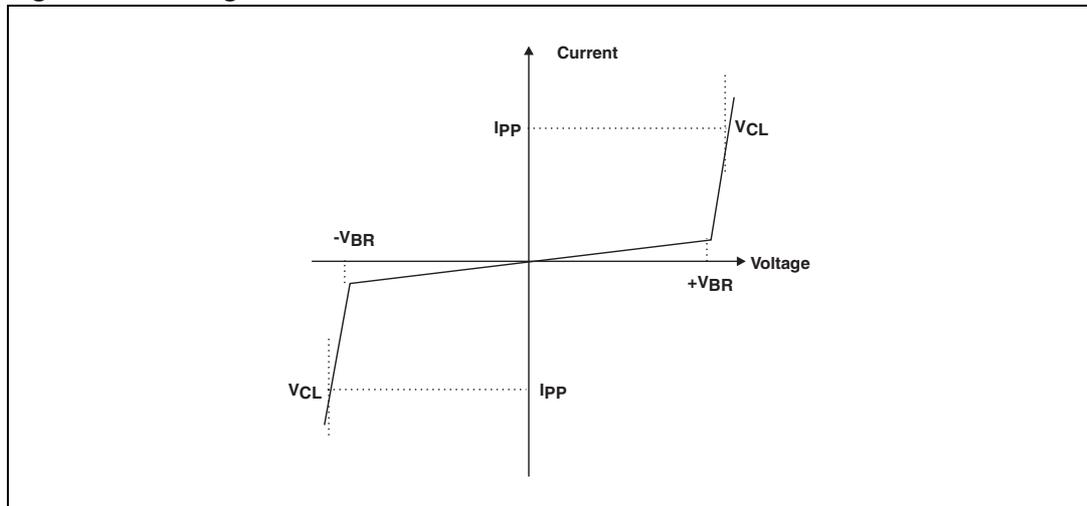

Figure 3. Voltage-current characteristic of a Transil diode



Note: V_{BR} is specified for a 1mA current.

V_{CL} clamping voltage is given for a high I_{pp} current level (from several amperes to several tens of amperes, depending on the device part-number).

Figure 4. shows the characteristic of the TRIAC + Transil assembly. This is the case of a 600 V/12 A TRIAC protected by a 376 V Transil diode. (The dotted line in Figure 4. shows the characteristic of the TRIAC alone).

Figure 4. Characteristic of the TRIAC + Transil assembly

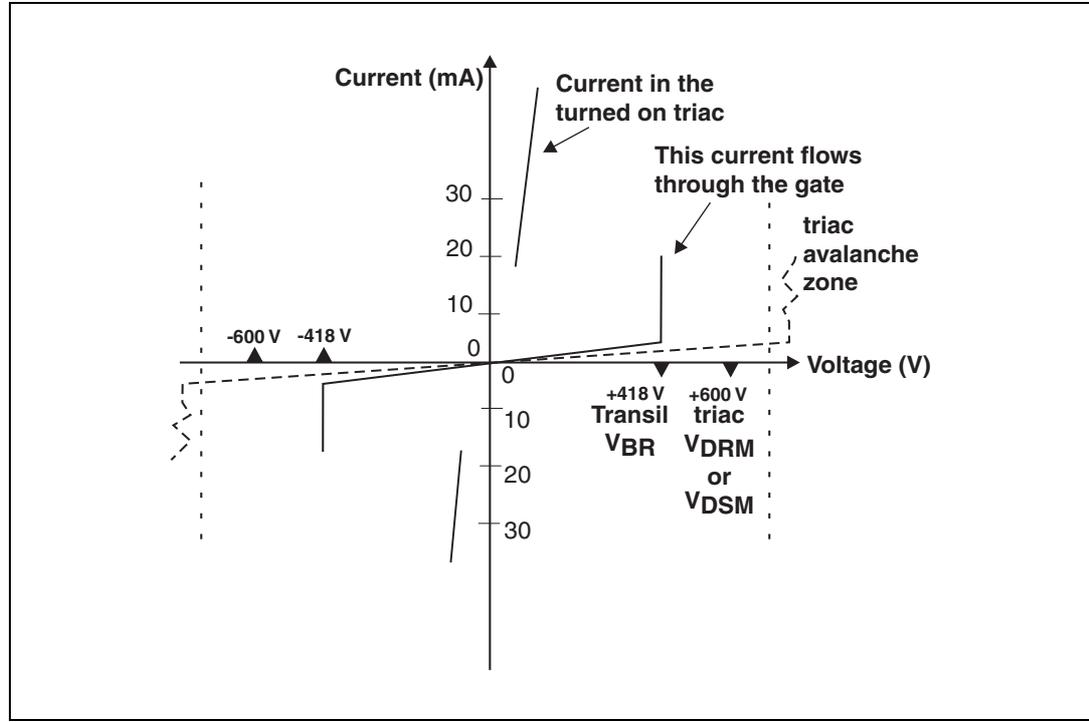

The advantages of this solution are the following:

- The TRIAC will always operate within the voltage limits given by the manufacturer (V_{DRM} ; V_{RRM} or V_{DSM} ; V_{RSM}) and thus far from the avalanche area. There is no more risk of TRIAC failure
- The TRIAC is turned on by a gate current which will ensure optimal di/dt conditions.

It should be noted that ST guarantees safe operation of their TRIACs even if the V_{DRM} and V_{RRM} levels are exceeded by 100 V during less than 10 ms. This behavior is guaranteed by the V_{DSM} and V_{RSM} parameters (refer to ST TRIAC datasheets). This allows an easier choice of voltage protection.

Figure 5. shows the behavior of a TRIAC protected by a Transil diode. The TRIAC is turned on by the gate at the beginning of the overvoltage and remains conducting until next zero current point.

Figure 5. Behavior of a TRIAC protected by a Transil diode

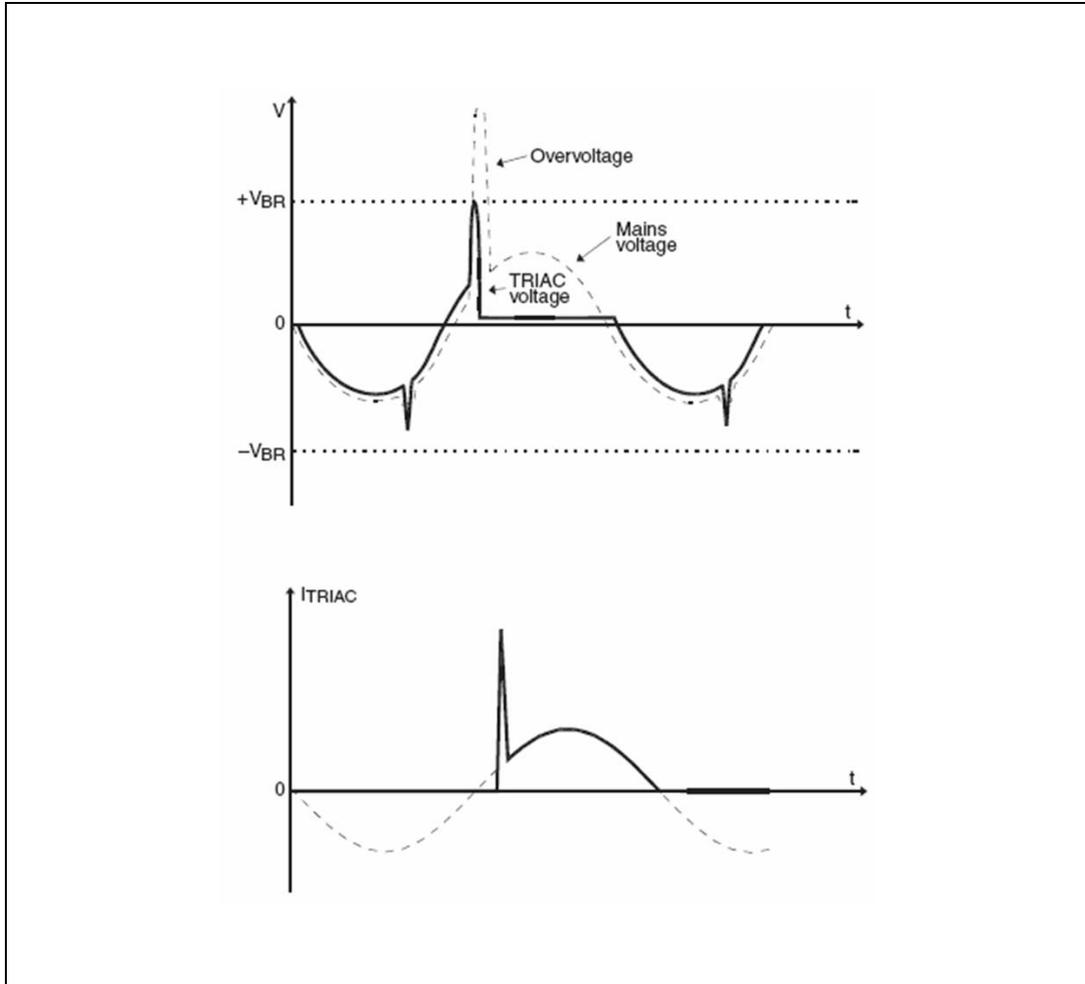

3 Transil choice for efficient TRIAC voltage protection

To choose the right Transil, two points have to be considered:

- First, the breakdown voltage of the Transil has to be high enough to ensure a low leakage current when the mains voltage is applied across its terminals, to avoid any TRIAC spurious turn-on in normal operating conditions.
- Secondly, the clamping voltage has to be low enough in order to ensure that the maximum voltage applied across TRIAC terminals will be lower than its V_{DSM} / V_{RSM} levels, in case of surge.

3.1 Normal operation: check V_{RM} voltage

The Transil has to be chosen so that its V_{RM} voltage is higher than the maximum peak voltage encountered in the application. This will prevent any TRIAC spurious turn-on.

To define the maximum peak voltage, first we have to define the highest rms line voltage. For European and most Asian countries, the line nominal rms voltage is in the range 220 to 240 V. Furthermore, this voltage is given within a $\pm 10\%$ maximum variation. This means that the highest peak voltage should be 373 V (as given by the calculation below).

For US and Japanese markets, the rms nominal voltage range is 100-120 V. This means that the maximum peak voltage is 187 V.

Example: 240 V_{rms} grid voltage

$$V_{RMS\ MAX} = (V_{RMS} \cdot 1.1) \cdot \sqrt{2} = 264 \cdot \sqrt{2} = 373\ V$$

For 240 V operation, the Transil V_{RM} has to be higher than 373 V. For example, a BZW04-376B Transil could be used. This means that for the highest peak voltage, the Transil leakage current will be always lower than the specified I_{RM} current, i.e. 1 μA for this specific BZW04-376B device.

For 120 V operation, a BZW04-239B Transil can be used.

The BZW04 Transils are through-hole components. For an SMD and 240 V application, there is no component available with a high enough peak voltage (the maximum available Transil V_{RM} is 188 V for SMD). Then, two SMAJ188CA-TR can be used in series.

The V_{RM} is then 376 V which is good for 240 V operation ($2 \times 188 = 376\ V$).

3.2 Surge voltage clamping: check max V_{CL} voltage

Before dealing with maximum clamping voltage, the Transil power rating has to be defined. First, we know that the Transil conducts only for the time to turn the TRIAC on. This conduction lasts approximately 1 μs . So the dissipated power remains well within the power capability of Transils. The BZW04 series (400 W) is suitable for most cases (refer to [Section 3.1](#)).

To define the maximum Transil clamping voltage, we have to define the current which is circulating through it before TRIAC turn-on. This current is the TRIAC gate current. The highest TRIAC gate current, required to turn-on a TRIAC in standard conditions, in all ST

product portfolio is 50 mA (we consider only Q1 and Q3 triggering as the TRIAC is triggered in these quadrants here).

Then, as I_{gt} is increasing when the temperature is decreasing, the required Transil current to turn on the TRIAC will be higher at low temperature. According to ST TRIAC datasheets, the I_{gt} could be up to 2.25 times higher for a $-40\text{ }^{\circ}\text{C}$ junction temperature.

This gives a maximum Transil current of: $I_{gt_{max}} @ -40\text{ }^{\circ}\text{C} = 115\text{ mA}$

The Transil current can be higher than 115 mA (as shown in [Section 4: Experimental validation example](#)). This phenomenon is due to the delay of the TRIAC to switch on. This delay is typically lower than $2\text{ }\mu\text{s}$. But during this time, even if the Transil clamps the voltage, the line voltage is still increasing. This results in a current increase through the Transil diode. This current is higher if the load impedance is lower, i.e. when the load power is higher. For a 2 kW load, the current can reach several amperes (refer to [Section 4: Experimental validation example](#)).

To identify the V_{CL} for such a current, [Figure 6.](#), given in Transil datasheets, can be used. This figure shows that for a current pulse width shorter than $20\text{ }\mu\text{s}$ (much higher than TRIAC turn-on time) and a peak current lower than 1 A, the Transil V_{CL} is around 550 V. So it is lower than most TRIACs V_{DSM} (700 V or 900 V).

Note that this figure is given for a $25\text{ }^{\circ}\text{C}$ initial junction temperature. For a higher initial temperature, you can use the temperature derating factor (α_T) given in Transils datasheet, as shown on the following formula. As the Transil is not operating before the surge, the initial temperature is the ambient temperature. As usually in industrial and appliance applications, the highest ambient temperature is $70\text{ }^{\circ}\text{C}$, the supplementary voltage is around 20 V for a BZW04-376B and so can be neglected.

For an SMD application two SMAJ188CA-TR can be used in series. The maximum V_{CL} has then to be calculated as twice the value read in the data sheet graph or with the V_{CL} value given for a 1.4 A peak current (328 V). This gives a maximum voltage of 656 V which is good even for 600 V TRIACs as ST guarantees a 700 V maximum peak voltage (refer to V_{DSM} , V_{RSM} parameters).

Figure 6. Clamping voltage versus peak pulse current

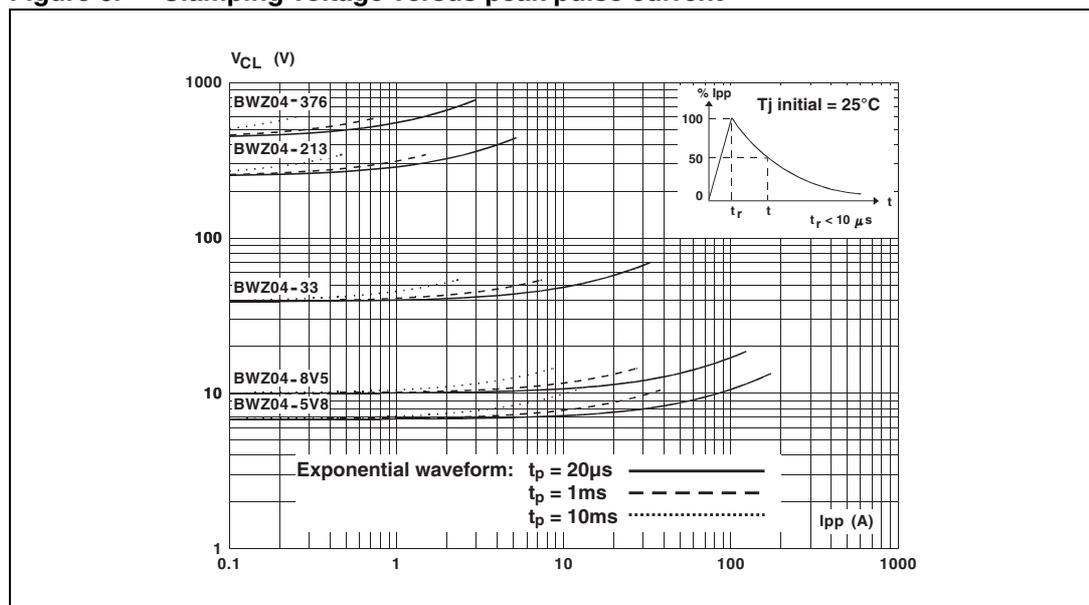

4 Experimental validation example

We give here a circuit example for a 2 kW heating element working on 230 V mains (see [Figure 7.](#)).

The BZW04-376B type Transil completely protects the TRIAC. Here a BTB16-600B is used ($V_{DRM} = \pm 600V$). The Transil V_{RM} level is 376 V. The 100Ω resistor R, between the gate and A1 is required to divert the current coming from the Transil in case of high dV/dt rates. Without it the TRIAC dV/dt capability may be reduced by up to 50%. This phenomenon is due to the junction capacitance of the Transil, which produces a parasitic current to the TRIAC gate in case of fast transient voltage applied between A1 and A2 terminals. A resistor lower than 100Ω is efficient enough with a BZW04, but with a 1.5KE Transil, a 47Ω resistor has to be used. For the 376 V V_{RM} the typical capacitance of a BZW04, measured at 0 V, is around 70 pF, compared to 360 pF for the 1.5KE. The parasitic capacitive current will then be much higher with the 1.5KE Transil.

Note that a snubber circuit could be added across the TRIAC to increase the circuit immunity towards fast voltages transient. 100Ω and 1 nF values should be used for the snubber resistor and the snubber capacitor respectively.

Figure 7. Practical Example of the Protection of a 16 A TRIAC against overvoltages

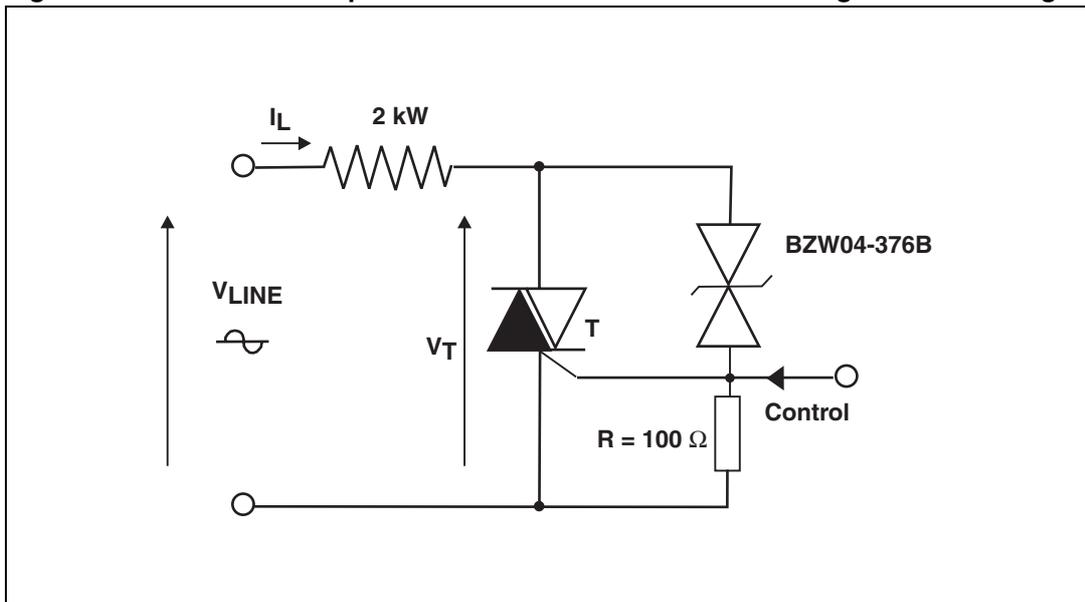

Figure 8. TRIAC turn-on after a 1 kV surge**Figure 9. TRIAC turn-on and turn-off after a 2 kV surge**

Figure 8. shows the overall wave shapes when the circuit in *Figure 7.* is tested according to IEC 61000-4-5 standard, with a 1 kV positive surge applied at positive peak line voltage. This figure shows that the TRIAC is turned on when the surge is applied and remains on until the load current (I_L) returns to zero. *Figure 9.* shows the same experiment but with a 2 kV surge. Here TRIAC T switches on but immediately switches back off because I_L crosses zero just after the surge. This phenomenon is due to the line voltage oscillations coming from the L-C resonant circuit of the coupler which is used to apply the surge to the line.

Figure 10. shows all the wave shapes at TRIAC turn-on for 2 kV surge. This figure shows that the TRIAC voltage V_T is limited to 512 V thanks to the BZW04-376B Transil, whereas the line voltage increases above 800 V. The load current, i.e the Transil current, is quite high (4 A) during the voltage clamping, due to TRIAC turn-on delay time.

Figure 11. shows the same but for a -2kV surge applied at negative peak mains voltage. Here the TRIAC turn-on delay is around 600 ns, compared to 100 ns for the positive surge. This longer delay is due to the fact that as it's more difficult to turn-on a TRIAC in quadrant

Q3 than in quadrant Q1. This longer delay leads to a higher Transil current before TRIAC turn-on. This current reaches 20 A. The voltage across the TRIAC is then higher (548 V compared to 512 V for the positive surge).

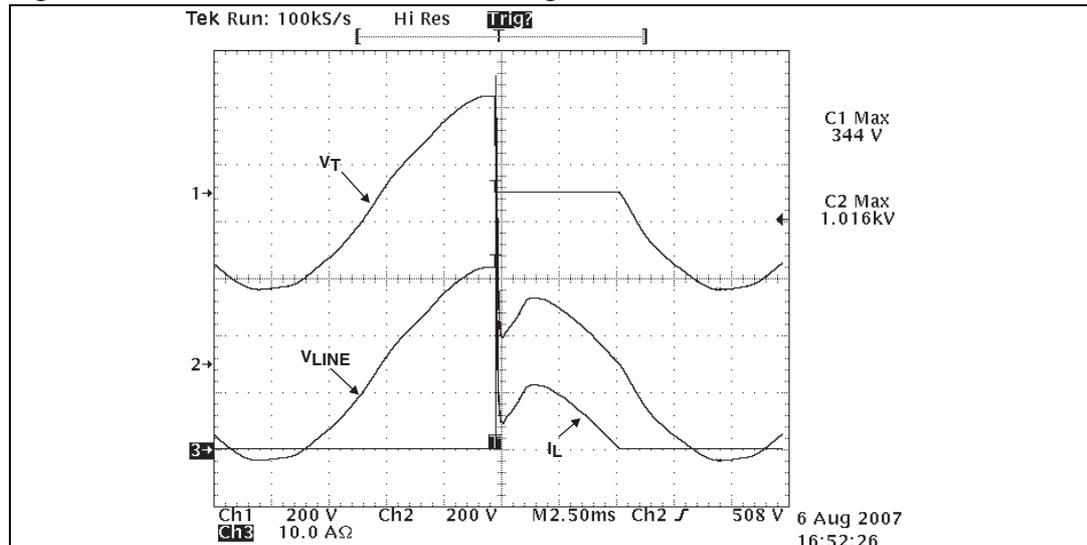
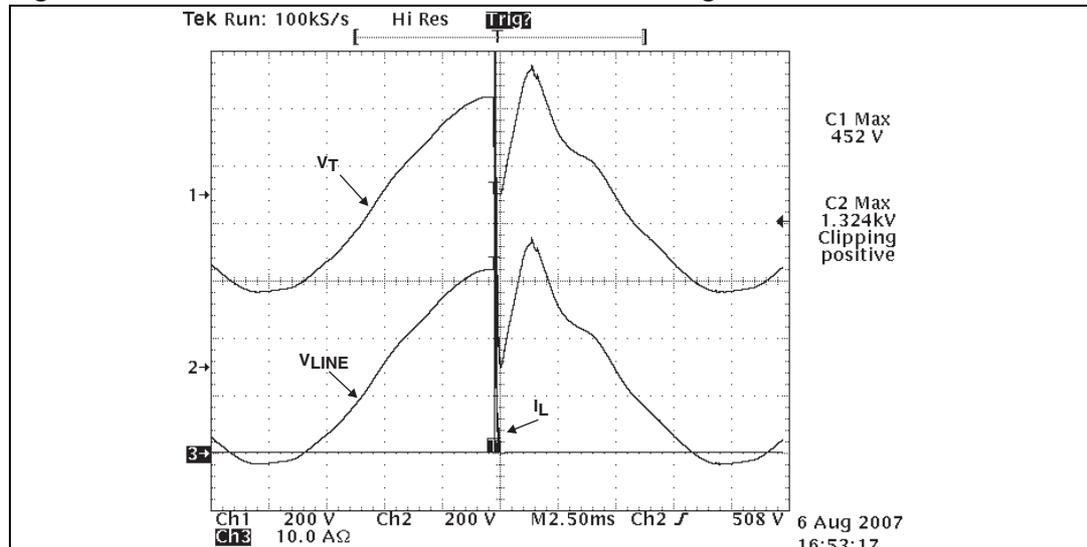
Note this current is quite high for a 400 W Transil. But according to Figure 2 of the BZW04 datasheet (“Peak pulse power versus exponential pulse duration”), the maximum peak power that the BZW04 is able to withstand is 40 kW for a 1 μs pulse width. Here the peak power is only 11 kW for a 600 ns triangular wave shape.

The clamping voltage is still below TRIAC V_{DSM} , so the operation is safe. In case of lower voltage margin, a higher power Transil can be used to limit the clamping voltage increase due to the load current. A higher power Transil can also be used if the peak dissipated power is too high.

Figure 10. TRIAC turn-on (+2 kV surge)

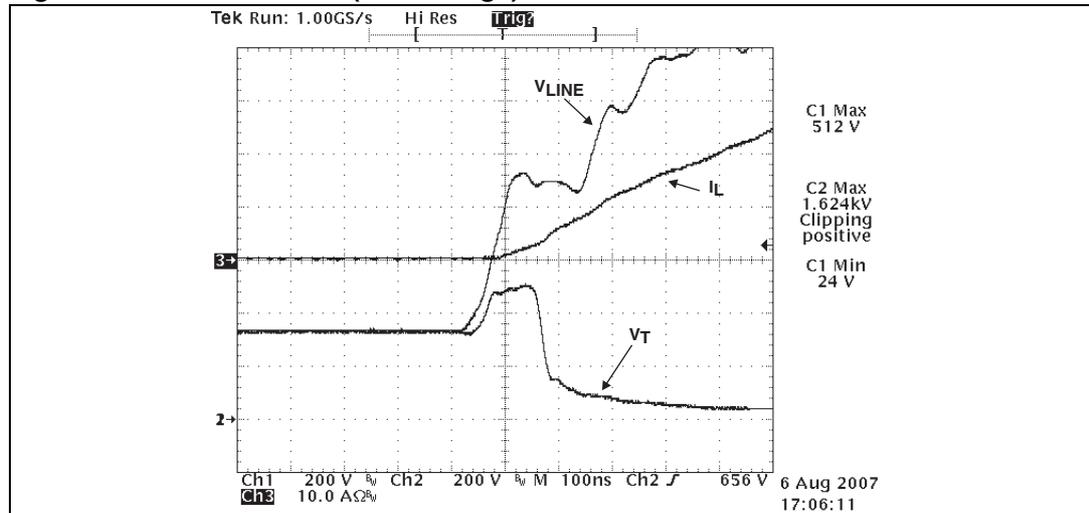

Figure 11. TRIAC turn-on (-2 kV surge)

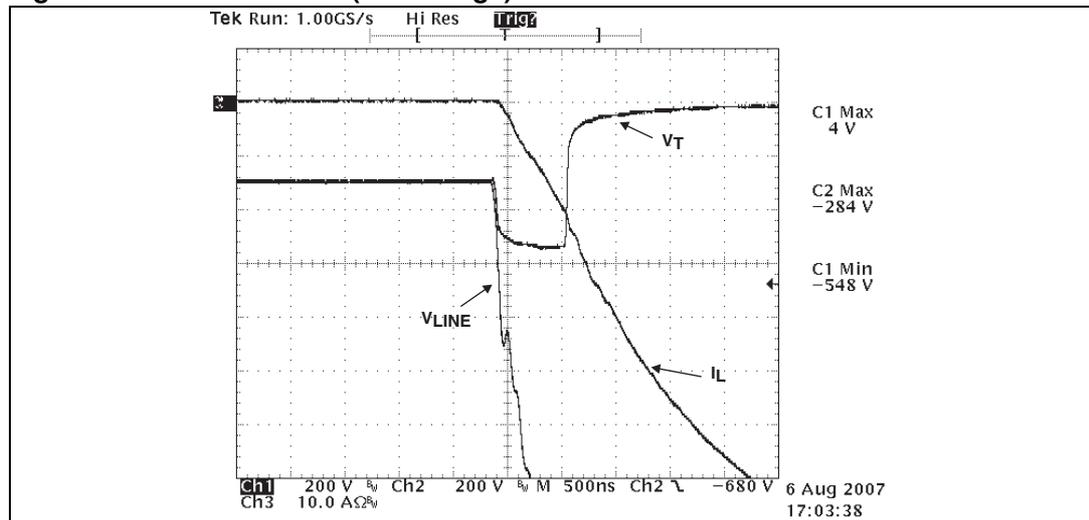

Figure 10. and *Figure 11.* show that the measured clamping voltages are much lower than the specified values. This could be explained by two points. First, these measurements are based on typical devices, and so do not cover our production dispersion. Secondly, the V_{CL} is specified for an 8/20 μs or a 10/1000 μs pulse shape. That means that the rise time and the fall time (back to 50% of the peak value) of the current are respectively 8 μs and 20 μs for the 8/20 wave shape. Here the current pulse lasts only a few hundreds of ns. The device has no time to heat up. The clamping voltage is then lower than the one specified for an 8/20 shape.

5 Conclusion

A procedure has been given to choose the right Transil for TRIAC protection. The minimum Transil V_{BR} is easy to define according to the targeted line voltage. To define the maximum clamping voltage, experimental results are recommended to check the maximum current which will flow through the Transil. This current is linked to the TRIAC turn-on delay, the line surge voltage shape and the load impedance. So the current value is difficult to estimate theoretically and it's better to perform tests to measure it. It should be noted that the value is then a typical one and a margin has to be added.

With the proposed protection circuit, the TRIAC voltage can be kept lower than the specified V_{DSM} and V_{RSM} limits, even in case of voltage surges. The only drawback is that the TRIAC is turned on as soon as the voltage exceeds the clamping level of the Transil. But this is the price to pay to avoid any TRIAC damage in case of turn-on in breakover mode. The turn-on is safe here as it is ensured by a gate current.

It should be noted that the spurious TRIAC turn-on only lasts a half-cycle (10 ms for 50 Hz operation). It could be accepted for most applications, especially for heating applications where a 10 ms switch on has no impact on the system behavior, as it could not be detected by the end user and have no impact on excessive heating or power consumption.

This circuit enables a considerable increase in systems reliability and is mandatory to implement with TRIACs driving high power resistive loads, where a varistor is not efficient enough. ST has also introduced ACS and ACST devices, which feature such overvoltage protection by crowbar. The protection is then directly integrated in the silicon die, and no other external device, such as Transil and resistor, is required.

6 Revision history

Table 1. Revision history

Date	Revision	Changes
1993	1	Initial release.
15-Apr-2004	2	Stylesheet update. No content change.
11-Oct-2007	3	Reformatted to current standards. Full revision for currently available devices.

Please Read Carefully:

Information in this document is provided solely in connection with ST products. STMicroelectronics NV and its subsidiaries ("ST") reserve the right to make changes, corrections, modifications or improvements, to this document, and the products and services described herein at any time, without notice.

All ST products are sold pursuant to ST's terms and conditions of sale.

Purchasers are solely responsible for the choice, selection and use of the ST products and services described herein, and ST assumes no liability whatsoever relating to the choice, selection or use of the ST products and services described herein.

No license, express or implied, by estoppel or otherwise, to any intellectual property rights is granted under this document. If any part of this document refers to any third party products or services it shall not be deemed a license grant by ST for the use of such third party products or services, or any intellectual property contained therein or considered as a warranty covering the use in any manner whatsoever of such third party products or services or any intellectual property contained therein.

UNLESS OTHERWISE SET FORTH IN ST'S TERMS AND CONDITIONS OF SALE ST DISCLAIMS ANY EXPRESS OR IMPLIED WARRANTY WITH RESPECT TO THE USE AND/OR SALE OF ST PRODUCTS INCLUDING WITHOUT LIMITATION IMPLIED WARRANTIES OF MERCHANTABILITY, FITNESS FOR A PARTICULAR PURPOSE (AND THEIR EQUIVALENTS UNDER THE LAWS OF ANY JURISDICTION), OR INFRINGEMENT OF ANY PATENT, COPYRIGHT OR OTHER INTELLECTUAL PROPERTY RIGHT.

UNLESS EXPRESSLY APPROVED IN WRITING BY AN AUTHORIZED ST REPRESENTATIVE, ST PRODUCTS ARE NOT RECOMMENDED, AUTHORIZED OR WARRANTED FOR USE IN MILITARY, AIR CRAFT, SPACE, LIFE SAVING, OR LIFE SUSTAINING APPLICATIONS, NOR IN PRODUCTS OR SYSTEMS WHERE FAILURE OR MALFUNCTION MAY RESULT IN PERSONAL INJURY, DEATH, OR SEVERE PROPERTY OR ENVIRONMENTAL DAMAGE. ST PRODUCTS WHICH ARE NOT SPECIFIED AS "AUTOMOTIVE GRADE" MAY ONLY BE USED IN AUTOMOTIVE APPLICATIONS AT USER'S OWN RISK.

Resale of ST products with provisions different from the statements and/or technical features set forth in this document shall immediately void any warranty granted by ST for the ST product or service described herein and shall not create or extend in any manner whatsoever, any liability of ST.

ST and the ST logo are trademarks or registered trademarks of ST in various countries.

Information in this document supersedes and replaces all information previously supplied.

The ST logo is a registered trademark of STMicroelectronics. All other names are the property of their respective owners.

© 2007 STMicroelectronics - All rights reserved

STMicroelectronics group of companies

Australia - Belgium - Brazil - Canada - China - Czech Republic - Finland - France - Germany - Hong Kong - India - Israel - Italy - Japan - Malaysia - Malta - Morocco - Singapore - Spain - Sweden - Switzerland - United Kingdom - United States of America

www.st.com